

마그네틱 센서

KT-05 Series



KT-06 Series



KT-07 Series



KT-09 Series



KT-11 Series



KT-13 Series



KT-15 Series



KT-16 Series



KT-20 Series



KT-21 Series



KT-31 Series
High Temp. Resistant



KT-32 Series



KT-32-EX Series

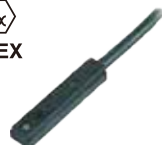

KT-33 Series



KT-36 Series
Compact Size



KT-37 Series
Compact Size



KT-38 Series
Compact Size



KT-40 Series



KT-47 Series



KT-48 Series



KT-50 Series
Patented



KT-53 Series



KT-58 Series



KT-59 Series



KT-65 Series
Patented



KT-65-EX Series
Patented



KT-65-UL Series
Patented



KT-71 Series



KT-75 Series
Patented



KT-77 Series



KT-1000D Series
Magnetic-Field Resistant



KT-1001D Series
Magnetic-Field Resistant



Bracket



Clamp



주문정보

K T - 0 6 R H - 1 M

센서 모델

센서 타입

R = 리드 스위치 2-와이어 타입
 RP = 리드 스위치 3-와이어 전류 소싱(Sourcing)
 RN = 리드 스위치 3-와이어 전류 싱킹(Sinking)
 P = 솔리드 스테이트 타입, 전류 소싱(PNP출력)
 N = 솔리드 스테이트 타입, 전류 싱킹(NPN출력)
 D = 솔리드 스테이트 타입, 2-와이어
 T = TRIAC 출력
 R - NC = REED / N.C
 P - NC = PNP / N.C
 N - NC = NPN / N.C

특별 표시

None = 표준 민감도
 H = 고민감도
 HH = 초고 민감도
 L = 저 민감도
 LL = 초저 민감도
 X = 지표 없음

케이블 길이 / QD핀아웃

★ 케이블 길이는 기본 1M 사양입니다.
 길이 1M이외는 문의를 부탁드립니다.
 ※ 단, 2M=KT-31R, 3M=KT-32-EX, KT-1000D, KT-1001D

QD = M8수(male)컨넥터
 EQD = M8 수(male)컨넥터
 1M = 케이블의 길이는 1미터 ★기본 사양
 2M = 케이블의 길이는 2미터
 3M = 케이블의 길이는 3미터
 5M = 케이블의 길이는 5미터
 10M = 케이블의 길이는 10미터

연결방법

1 2 와이어 센서 연결

■ 일반연결 (리드 스위치)

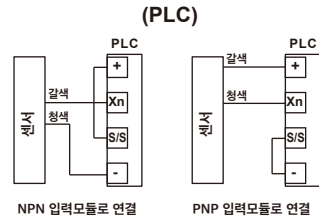
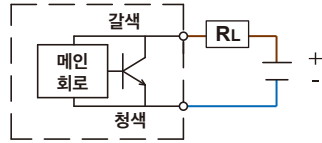
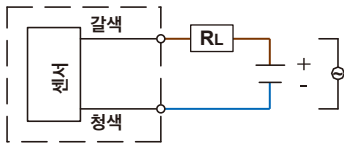

■ 직렬 연결 (AND)



2-와이어 센서들을 직렬 (AND)로 연결할 때는 내부전압강하(보통전압강하 = 스위치 마다 2.5~4 V) 때문에 2개 이상의 스위치를 연결하지 않습니다. 급격한 전압강하로 인해 부하가 작동하지 않을 수 있습니다.

1. 솔리드스테이트 2-와이어 센서를 병렬(OR)로 연결할 경우, 누설전류가 증가하고 부적합한 부하작동을 초래할 수 있습니다.
2. 2-와이어 리드센서를 병렬(OR)로 연결할 경우, 동시 작동으로 인한 낮은 전류분배로 LED 조명이 어두워집니다.

■ 병렬 연결 (OR)



2 3 와이어 NPN 연결

■ 일반연결

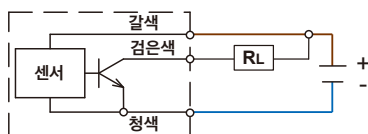

■ 직렬 연결 (AND)



■ 병렬 연결 (OR)





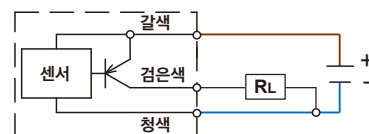









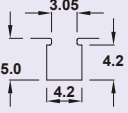

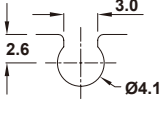

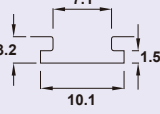

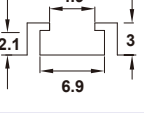

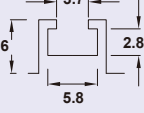

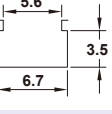
3 3 와이어 PNP 연결

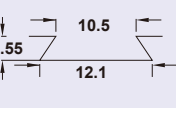

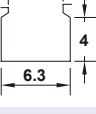
마그네틱 센서 Cross Index

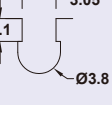

MODEL	KT-05	KT-06	KT-07	KT-09	KT-11	KT-13	KT-15	KT-16	KT-20	KT-21	KT-31	KT-32 KT-32-EX
Round Cylinder 	● BK Clamp		● BKC-1 Clamp				● BK Clamp		● PN / PH Clamp	● PN / PH Clamp		
ISO Profile Cylinder 			● PF7 Bracket					● PF7 Bracket	● PI Bracket	● PI Bracket	● PI Bracket	● PF Bracket
Tie-Rod Cylinder 			● DT7 Bracket	●		●		● DT7 Bracket	● PM Bracket	● PM Bracket	● PM Bracket	● DT Bracket FST Clamp
 4 x 4 Solt 		●										
 SMC C Solt 			●					●				
 KOGANEI T Solt 					●							
 SMC T Solt 												
 SMC T Solt 												
 FESTO T Solt 			● PB Bracket					● PB Bracket				●
 Dovetail Solt 												
 SMC T Solt 			● PB Bracket					● PB Bracket				
 FESTO C Solt 												
 AIRTAC 4 x 4 Slot 												

* 상기 이미지는 참고용이며, 사이즈는 실린더 제조사에 따라 달라 질 수 있습니다.



KT-33	KT-36	KT-37	KT-38	KT-40	KT-47	KT-48	KT-50	KT-53	KT-58	KT-59	KT-65 KT-65-EX KT-65-JL	KT-71	KT-75	KT-77	KT-1000D	KT-1001D
	BKC-1 Bracket			BL-1 Clamp		BS Clamp	BL-1 Clamp				BKT-1 Clamp		BKT-1 Clamp	BKC-1 Clamp	BP Clamp PMB Bracket	
	PF7 Bracket	PF7 Bracket	PF7 Bracket	PF Bracket			PF Bracket				PF Bracket		PF Bracket	PF7 Bracket		
	DT7 Bracket	DT7 Bracket	DT7 Bracket	DT Bracket FST Clamp			DT Bracket FST Clamp				DT Bracket FST Clamp		DT Bracket FST Clamp	DT7 Bracket		
																PB Bracket
	PB Bracket	PB Bracket	PB Bracket											PB Bracket		PB Bracket

04
센서
KT

- KT-05~
- KT-11~
- KT-20~
- KT-31~
- KT-40~
- KT-50~
- KT-65~
- KT-71~
- KT-1000~
- BRACKET
- CLAMP
- KP75
- MPS-37
- MPS-38
- MPS-51E

마그네틱 센서 작동과 설치방법

리드 SW.타입

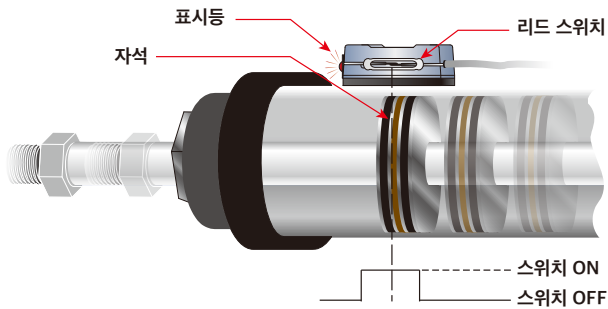

피스톤의 자석이 마그네틱 센서에 접근할 경우, 내부 리드 스위치가 자기장의 변화를 감지하여 접촉을 차단합니다.

솔리드스테이트 타입

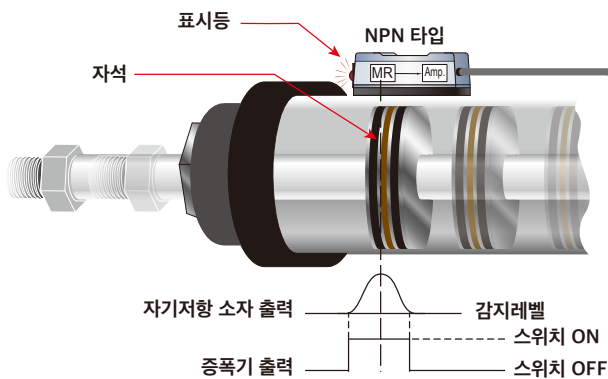

모델: TS-2

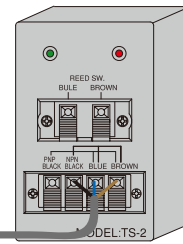

피스톤 자석이 자기센서에 접근하면 내부자기저항소자가 자기장의 변화를 감지하여 미세한 전압의 변화를 일으킬 수 있습니다. 신호가 자기센서의 연산증폭기 회로에 의해 증폭될 때 스위칭 출력이 이루어집니다.

마그네틱 센서 설치 방법

1 스트로크 말단 감지

- 1단계 : 스트로크 끝에 피스톤을 설치한다.

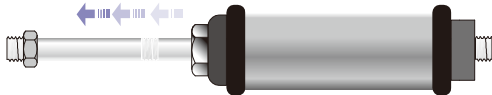

- 2단계 : 마그네틱 센서를 앞으로 밀고 실린더 벽에 가깝게 유지시킨다. 센서가 켜지는 지점에 표시한다.

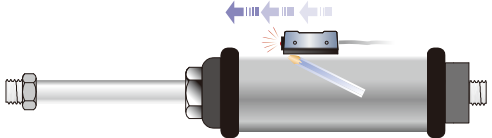

- 3단계 : 센서가 꺼질 때까지 센서를 계속 앞으로 민다.

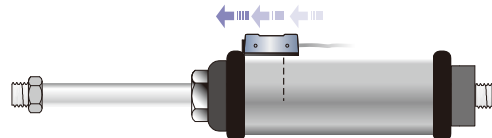

- 4단계 : 센서가 다시 켜질 때까지 센서를 뒤로 밀고 표시한다.

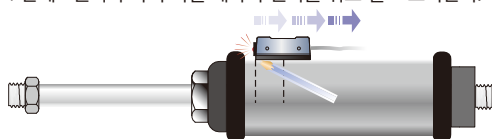

- 5단계 : 두 개의 표시 사이의 중간 위치가 가장 이상적인 위치입니다.

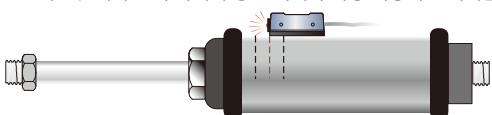

2 중간 스트로크 위치

- 1단계 : 요구되는 위치에 피스톤을 놓는다.



- 2단계 : 마그네틱 센서를 앞으로 밀고 실린더 벽에 가깝도록 유지시킨다. 센서가 켜지는 지점에 표시한다.

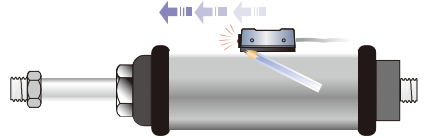

- 3단계 : 센서가 꺼질 때까지 센서를 계속 앞으로 민다.

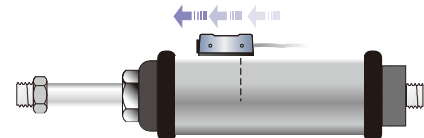

- 4단계 : 센서가 다시 켜질 때까지 센서를 뒤로 밀고 표시한다.

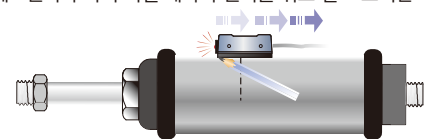

- 5단계 : 두 개의 표시 사이의 중간 위치가 가장 이상적인 위치입니다.

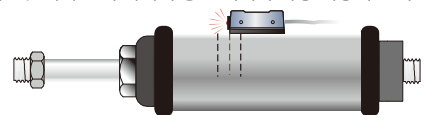

주의사항

1 사양을 초과해서 사용하지 마십시오. 센서가 영구적으로 손상될 수 있습니다.

2 리드 센서 타입의 경우 LED의 적절한 기능을 위해 극성을 반드시 맞춰야 합니다. 부하에 직렬인 갈색 와이어를 전원의 양극(+)에 연결하고 청색 와이어를 전원의 음극(-)에 연결하십시오. 극성이 바뀌면 리드센서는 계속 작동하지만 LED는 "OFF"상태를 유지할 것입니다.

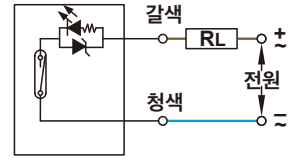

3 솔리드 스테이트 타입 센서의 경우는 극성을 반드시 맞춰야 합니다. 갈색 와이어를 DC 전원의 양극(+)에, 청색 와이어를 음극(-)에 연결합니다. 검은색 와이어는 반드시 부하에만 연결해야 합니다. 검은색 와이어가 전원에 연결되면 센서가 영구적으로 손상될 수 있습니다.

(NPN Output)

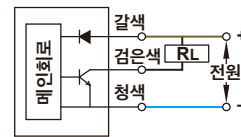

(PNP Output)

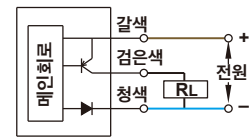

4 자기센서가 릴레이 또는 솔레노이드와 같은 유도부하와 함께 사용된다면 외부보호회로가 필요할 수 있습니다. DC 유도부하의 경우는 외부다이오드를 부하에 병렬로 부착하고 우측 그림과 같이 AC 유도부하와 병렬로 R-C 회로를 사용합니다.

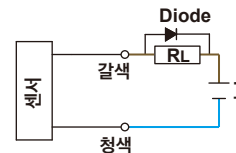

$$C = I^2 / 10 \text{ [}\mu\text{F]}$$

$$R = E / 10 I (1 + 50/E) \text{ [}\Omega\text{]}$$

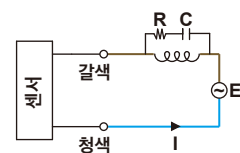

PS :
C : 캐패시터 I : 부하전류
R : 저항 E : AC전원

5 오작동을 방지하기 위해 센서를 강한 자기장으로부터 멀리 위치시킵니다.

6 용량성 부하를 지닌 리드센서를 사용하거나 리드와이어의 길이가 10미터를 초과하는 경우, 손상(들러붙는 효과)을 방지하기 위하여 인덕터(560~1000 μ H) 또는 SR-1(서지억제기)을 반드시 센서와 직렬로 설치해야 합니다.

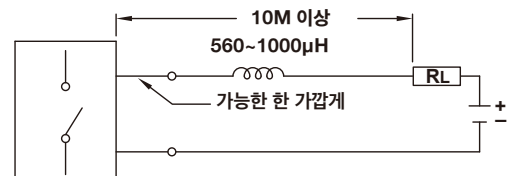

■ 모델: SR-1 (서지 억제기)

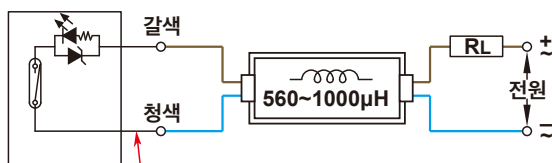

SR-1과 센서는 가능한 한 가깝게 케이블로 연결되어야 함

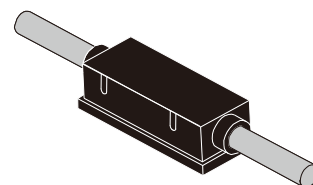

■ 치수

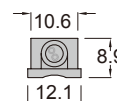
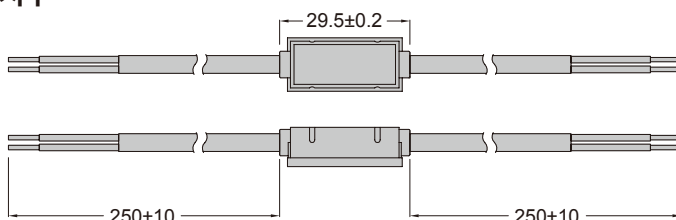

단위 : mm

제품 통합

KT-07 & KT-16 시리즈



- 대부분의 C-슬롯 실린더에 맞으며 모든 T-슬롯센서와 교체 가능하여 고객의 재고 품목을 감소시킴

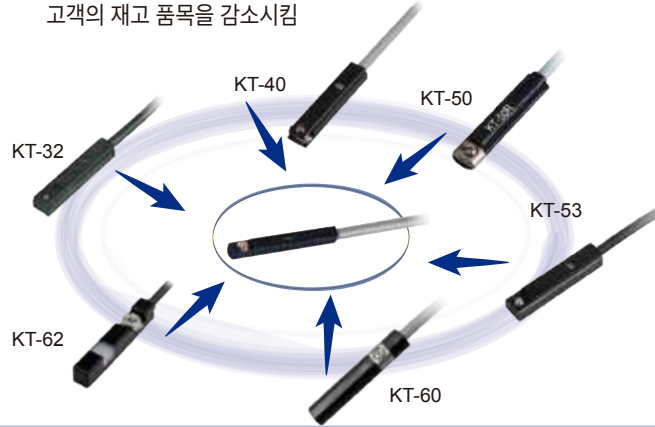

일반 실린더 슬롯의 치수

※ C-슬롯 실린더의 치수

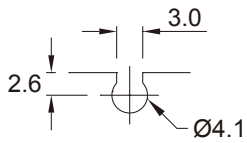

※ T-슬롯 실린더의 치수

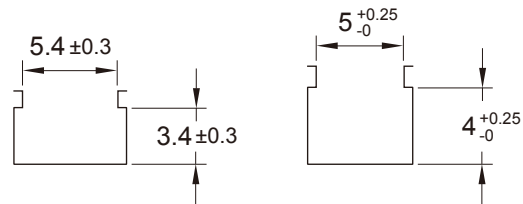

다른 타입의 실린더에 어댑터 장착

- 여러 종류의 실린더에 적용

PF7 브라켓을 ISO 프로파일 실린더에 장착



BKC-1 클램프를 라운드 실린더에 장착



C-슬롯실린더



DT7 브라켓을 타이로드 실린더에 장착



PB 브라켓을 T-슬롯 실린더에 장착



KT-07 & KT-16 시리즈

새로운 구조

KT-65 & KT-75 시리즈

- 세트스크류는 센서가 움직이지 않도록 중심 가까이 위치하며, 실린더에 장착시에 견고한 자세를 만들기 위해 새로운 세트스크류에 결합됨

센서의 이동을 방지하기 위해 중앙에 스크류를 설계함



- 대부분의 T-슬롯에 맞으며 모든 T-슬롯센서와 교체 가능하며 고객의 재고품목을 감소시킴

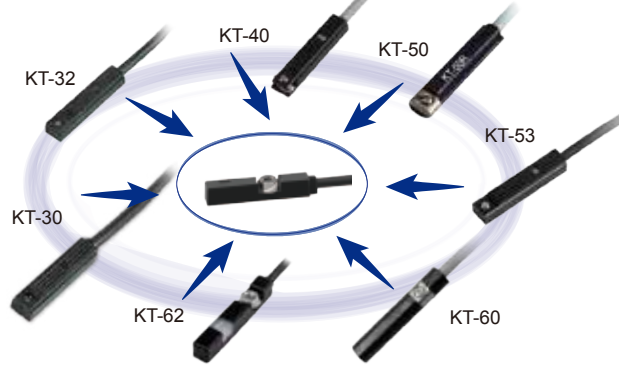

새로운 구조

- 센서는 실린더의 상부에서 T-슬롯에 직접 놓여져 빠르게 설치 가능

1 설치

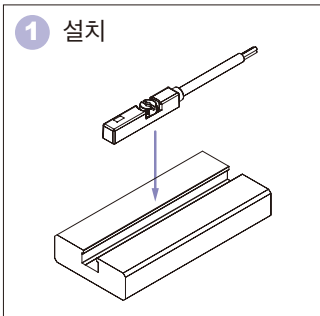

2 잠금

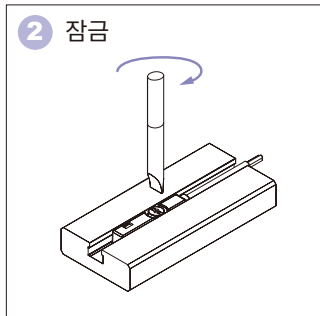

※ T-슬롯 실린더의 치수

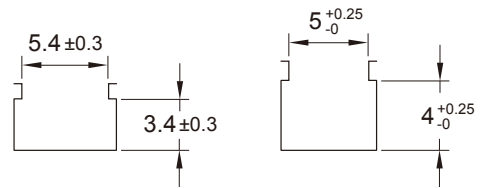

다른 타입의 실린더에 어댑터 장착

- 여러 종류의 실린더에 적용

PF 브라켓을 ISO 프로파일 실린더에 장착



FST 클램프를 타이로드 실린더에 장착



BKT-1 클램프를 라운드 실린더에 장착



DT 브라켓을 타이로드 실린더에 장착



T-슬롯실린더



KT-65 & KT-75 시리즈